

## COMBi-RT

The Combi-RT forklift is designed for use on rough terrain, catering to your poultry and agri needs.

# COMBiLiFT

LIFTING INNOVATION



ncnielsen

# COMBi-RT

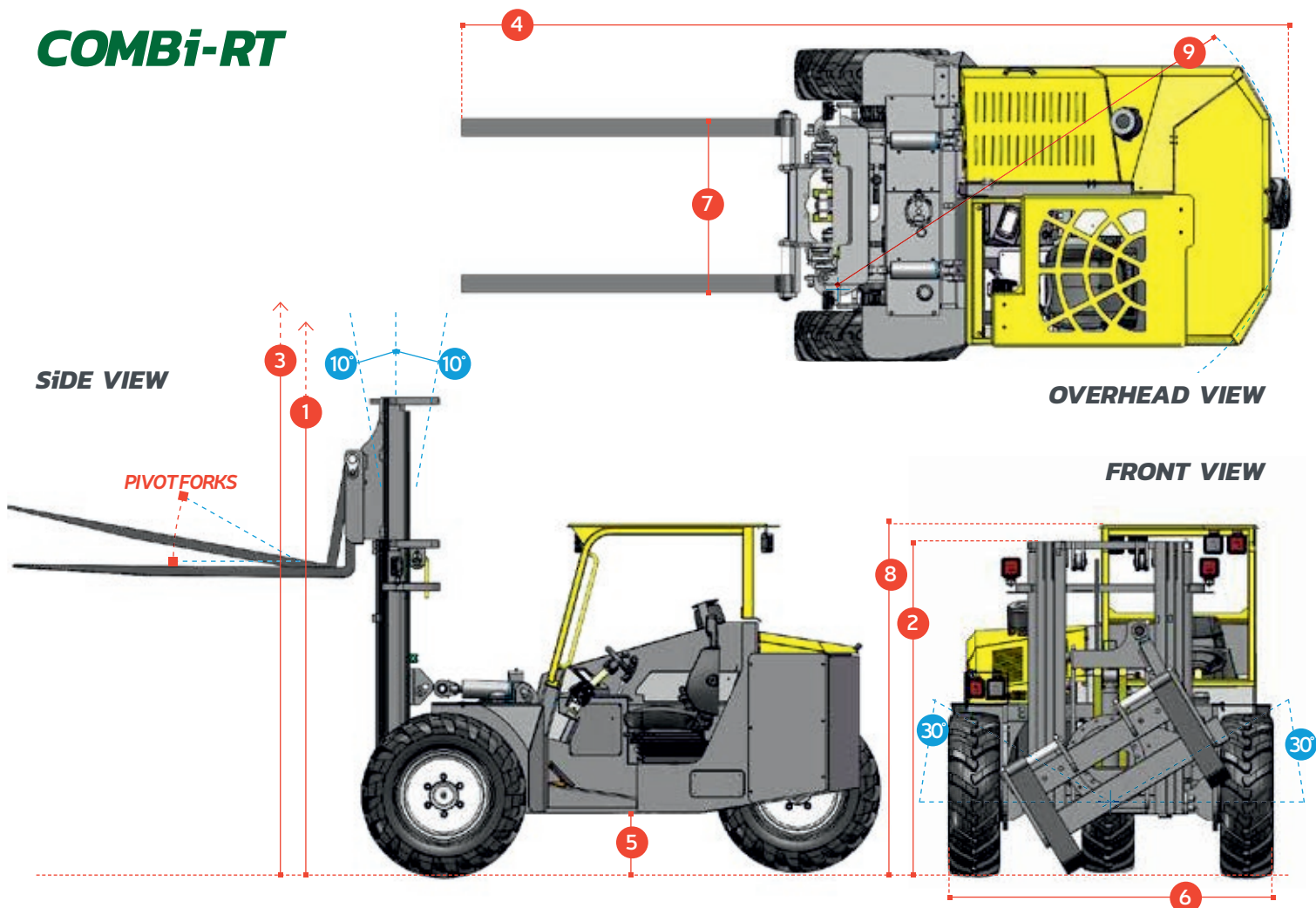

REF.	DESCRIPTION	
1	Max. Lift Height	3150mm
2	Height Mast Closed	1810mm
3	Max. (Mast raised)	4145mm
4	Overall Length	4660mm
5	Ground Clearance	300mm

REF.	DESCRIPTION	
6	Width	1800/2000mm
7	Outside Spread of Fork Arms	1000mm
8	Truck Height	1880mm
9	Turning Radius	2345mm

DESCRIPTION	Kubota 44 kW	Kubota 74 kW
Capacity	1500 kg @ 1200 mm	1600 kg @ 1200 mm
Unladen Weight	4450 kg	4650 kg
Ground Speed	14 km/h	18 km/h
Gradeability	40%	
Kubota Water Cooled Diesel Engine	44 kW	74 kW
Overall Width	1800 mm	2000 mm
Electrics	12 Volt	
Triplex Mast Lift Height	3150mm	
Pivot Fork Section	50 mm x 100 mm x 1830mm	
Fork Rotation	-	30° each way
Pneumatic Tractor Grip Tyres	ø 910 mm width 290 mm	
Fuel Tank Capacity	85 litres	
Hydraulic Tank Capacity	75 litres	

## Features Include:

- 3 wheel maneuverability
- Hydrostatic all wheel drive
- Large tractor grip tyres
- Deep suspension seat
- Back up alarm
- 150 mm / 6" mast side shift
- Pivot Forks

## Benefits:

- Small turning radius
- Reduced maintenance costs
- No mechanical brakes to adjust or replace
- Large ground clearance

- I
- Offset driving position gives excellent visibility
- Ergonomically designed cabin for operator comfort

COMBILIFT HAS A POLICY OF CONTINUOUS PRODUCT DEVELOPMENT AND RESERVES THE RIGHT TO ALTER SPECIFICATIONS WITHOUT PRIOR NOTICE. SPECIFICATIONS AND/OR DIMENSIONS MAY VARY FROM THOSE ILLUSTRATED IN SOME COUNTRIES.

**ncnielsen**

Nørregade 66 • 7860 Balling  
Telefon 99 83 83 83 • www.nc-nielsen.dk • info@nc-nielsen.dk

**nc-nielsen.dk**